

(CBSGS)(R-2012)

(3 hours)

[Total marks: 80]

- N.B.: 1) Q. No. 1 is compulsory.
2) Attempt any three questions out of remaining five questions.
3) Assume suitable data if required.

- Q1 a) Explain wire frame modeling, surface modeling and solid modeling. 10
b) Write a manual part program for finishing a forged component as shown in Fig. 1. Assume the spindle speed and feed for machining as 500 rpm and 0.3 mm/rev respectively. 10

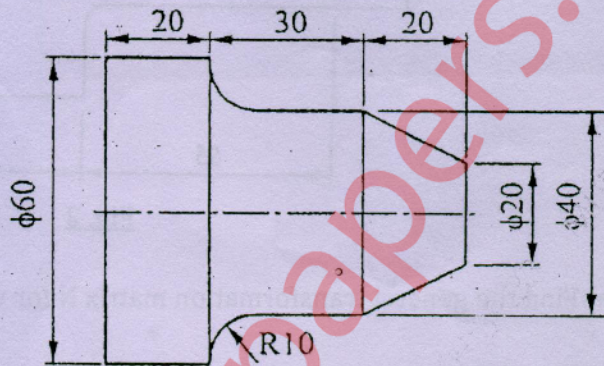

Fig. 1

- Q2 a) A Hermite cubic spline is defined by points (1, 1) and (6, 5), having tangent vectors as (0, 4) and (4, 0) respectively. Find the co-ordinates of parametric mid-point and slope at the same point. 10
b) Explain AS/RS and their types. 10

Q3 a) Find the co-ordinates of a triangle A (50, 20), B (110, 20) and C (80, 60), if it is reflected about; i) X-axis and ii) Line $y = x$. 10

Q4 a) Explain the role of CIM elements. 10

Q5 a) Find the transformation matrix which aligns vector K along positive z-axis with vector $V = aI + bJ + cK$. 10

Q6 a) The steps involved in rapid prototyping, list the various rapid prototyping technologies and explain Stereo-lithography in detail. 10

Q3 a) Find the transformed co-ordinates of a triangle A (50, 20), B (110, 20) and C (80, 60), if it is reflected about; i) X-axis and ii) Line $y = x$. 10

Q4 a) Explain the role of CIM elements. 10

Q5 a) Find the transformation matrix which aligns vector K along positive z-axis with vector $V = aI + bJ + cK$. 10

Q6 a) The steps involved in rapid prototyping, list the various rapid prototyping technologies and explain Stereo-lithography in detail. 10

[P.T.O.]

- Q5 a) Write a complete APT part program to machine the outline of the geometry and drill a hole as shown in Fig. 2. The component is 5 mm thick. The end mill used is 10 mm in diameter and suitable drill. Assume suitable speed and feed for machining. 12

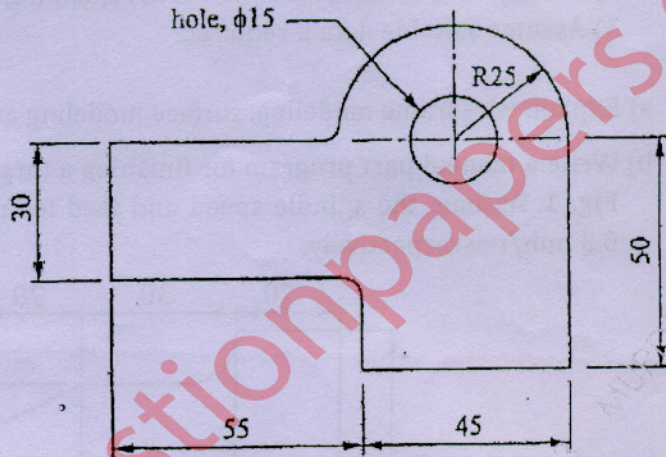

Fig. 2

- b) Find the general transformation matrix N for window to viewport mapping. 8
- Q6 Write short notes on; 20
- Knowledge based Engineering
 - Computer Aided Engineering
 - CIM Hardware and Software
 - Rapid Prototyping Applications